

Preliminary

LL-509RGBM2E-019

DATA SHEET



QC: 王士光

ENG: 謝嶽銳

Prepared By: 王新飛

Part No.	LL-509RGBM2E-019	Spec No.	S/N-04022602	Page	6 of 1
----------	------------------	----------	--------------	------	--------

Features:

- ◆ High intensity
- ◆ Standard 5mm diameter package
- ◆ General purpose leads
- ◆ Pb-free

Package Dimensions:

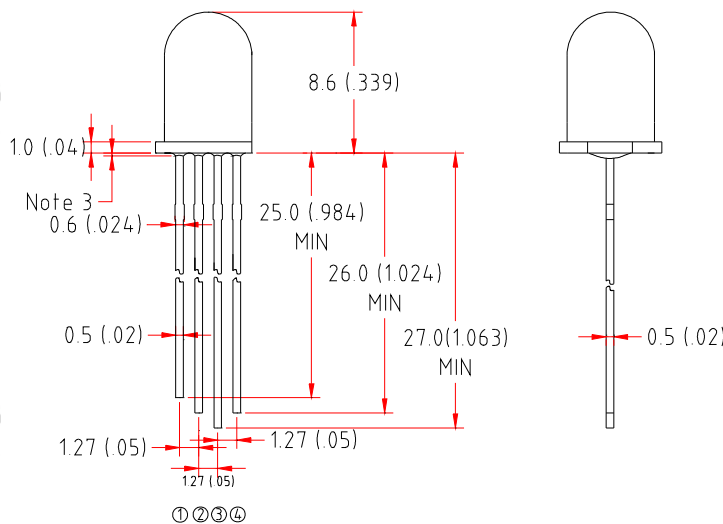
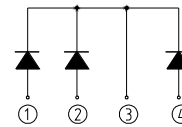
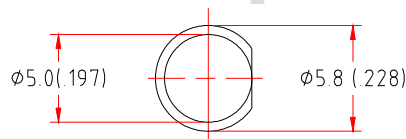

- ① True Green Anode
- ② Red Anode
- ③ Common Cathode
- ④ Blue Anode

Part NO.	Chip Material			Lens Color	Emission Color
	Red	True Green	Blue		
LL-509RGBM 2E-019	AlGaInP	InGaN	InGaN	White Diffused	Red & True Green & Blue

Notes:

1. All dimensions are in millimeters (inches).
2. Tolerance is $\pm 0.25\text{mm}$ (.010") unless otherwise noted.
3. Protruded resin under lens is 1.0mm (.04") max.
4. Lead spacing is measured where the leads emerge from the package.
5. Specifications are subject to change without notice.

6. Precautions for ESD:

Static electricity and surge can damages the LED. It is recommended to use a wrist band or anti-electrostatic glove when handling the LED. All devices, equipment and machinery must be properly grounded.

7. This data-sheet only valid for six months.



Absolute Maximum Ratings at Ta=25°C

Parameter	MAX.		Unit
	Power Dissipation	Red	
	True Green	80	
	Blue	80	
Peak Forward Current (1/10 Duty Cycle, 0.1ms Pulse Width)	100		mA
Continuous Forward Current	Red	35	mA
	True Green	20	
	Blue	20	
Derating Linear From 50°C	0.4		mA/°C
Reverse Voltage	5		V
Electrostatic Discharge (ESD)	150		V
Operating Temperature Range	-30°C to +80°C		
Storage Temperature Range	-40°C to +100°C		
Lead Soldering Temperature [4mm(.157") From Body]	260°C for 5 Seconds		



Electrical Optical Characteristics at Ta=25°C

Parameter	Symbol	Emitting Color	Min.	Typ.	Max.	Unit	Test Condition
Luminous Intensity	Iv	Red	150	320		mcd	I _F =20mA Note 1
		True Green	460	900			
		Blue	140	280			
Viewing Angle	2θ _{1/2}	Red	35	40	45	Deg	Note 2
		True Green	35	40	45		
		Blue	35	40	45		
Peak Emission Wavelength	λ _p	Red	640	645	650	nm	Measurement @Peak
		True Green	520	525	530		
		Blue	463	468	473		
Dominant Wavelength	λ _d	Red	625	630	635	nm	Note 3
		True Green	525	530	540		
		Blue	460	470	480		
Spectral Line Half-Width	Δλ	Red	15	20	25	nm	
		True Green	35	40	45		
		Blue	20	25	30		
Forward Voltage	V _F	Red	1.6	1.95	2.5	V	I _F =20mA
		True Green	2.8	3.2	4.0		
		Blue	2.8	3.5	4.0		
Reverse Current	I _R	Red			50	μA	V _R =5V
		True Green					
		Blue					

Note:

- Luminous intensity is measured with a light sensor and filter combination that approximates the CIE eye-response curve.
- θ_{1/2} is the off-axis angle at which the luminous intensity is half the axial luminous intensity.
- The dominant wavelength (λ_d) is derived from the CIE chromaticity diagram and represents the single wavelength which defines the color of the device.
- Forward voltage measurement allowance is ±0.1V
- Luminous Intensity Measurement Allowance is ±10%



Typical Electrical / Optical Characteristics Curves (25°C Ambient Temperature unless Otherwise Noted)

Spectral Radiance True Green Peak @ 525nm
Red Peak @ 645nm
Blue Peak @ 468nm

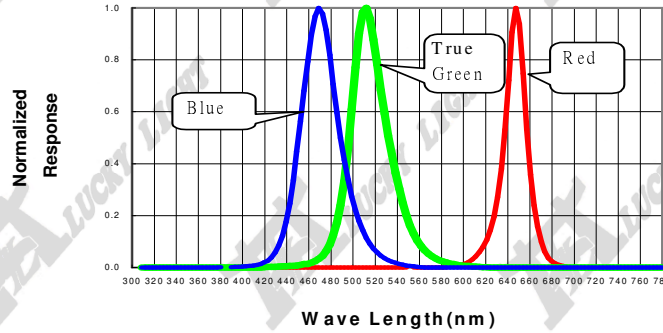

Forward Current vs Forward Voltage

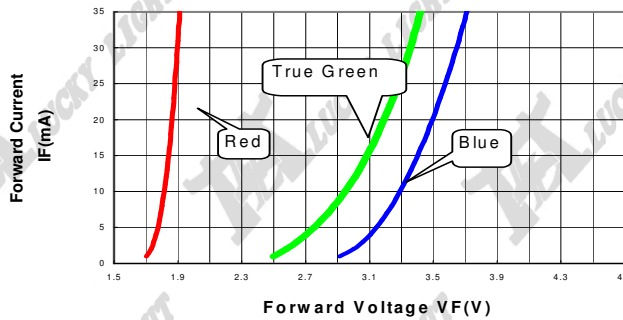

Relative Luminous Intensity vs Forward Current

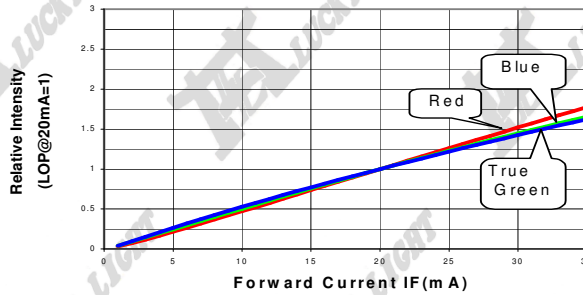

Beam Pattern

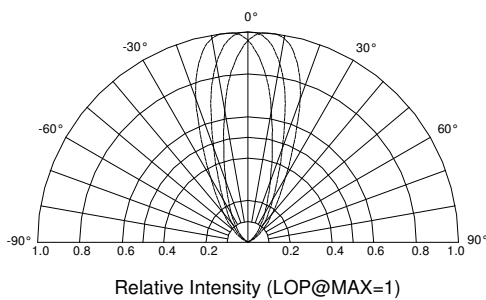

Forward Current Derating Curve

